

FIELD TESTS ON HEAT EXCHANGERS EQUIPPED WITH DUAL ENHANCED TUBES IN A QUENCH WATER APPLICATION

J. Provost, Technip, Paris, France¹
J. El-Hajal, Wieland-Werke AG, Ulm, Germany²
T. Lang, Wieland-Werke AG, Ulm, Germany²

¹ TECHNIP France, 92400 Courbevoie, France
² Wieland-Werke AG, 89079 Ulm

ABSTRACT

Dual enhanced tubes are widely used in many industrial areas but they have become a standard in several clean applications in hydrocarbon processing industry over the last 15 years only.

Although benefits are expected for applications with fouling process conditions, operators as well as manufacturers face the lack of operating data with dual enhanced tubes.

Strong of their success with dual enhanced tubes, Technip and Wieland have found the possibility to test the GEWA-PB tubes in industrial conditions thanks to a well-known European operator.

In an ethylene plant, an existing reboiler installed at the bottom of the C3 stripping column has been replaced by a new heat exchanger equipped with dual enhanced tubes. This reboiler uses quench water to provide the necessary energy to the column. Quench water is well known to be a fouling fluid but remains mainly unknown as it covers many different compositions.

The new heat exchanger was installed and started up in Fall 2012. Operating data have been recorded over more than 11 months. According to two different data analysis methods, no fouling inside the exchanger has been noticed and the operator has been able to maintain its production at a high level.

INTRODUCTION

Low-finned and dual enhanced tubes are widely accepted as standard solution in shell and tube heat exchangers in many industries such as the air-conditioning, power generation, hydrocarbon processing as well as machinery and equipment industry. Most of the considered applications are clean and the process conditions are controlled. If necessary, adequate protection, mitigation and cleaning strategies are considered.

For the hydrocarbon processing industry, substantial progress has been made in the recent years towards the qualification of enhanced heat transfer technologies for clean

services in key reboiler and condenser heat exchangers both in refrigeration and thermal distillation processes, e.g. in natural gas liquefaction and ethylene plants. However there is still a significant uncertainty towards broad application, especially in fouling applications. For these key applications it is very attractive to further investigate the behaviour of enhanced heat transfer technologies in open-loop cooling water and quench water environments.

Besides laboratory testing the key for an industrial application is the proof of the concept and qualification in the field. The fouling behaviour of a Wieland dual enhanced GEWA-PB tube has been investigated in a recent field trial with quench water. A tube bundle has been installed in an ethylene plant during the shut-down as a reboiler in a C3 stripper unit. The heating on the tube side of the reboiler was realized by quench water. The field data results are presented as well as the implication on the design.

The limiting factor using low-fin and dual enhanced tubes is in many cases the lack of information on the behaviour in fouling situations. Especially in the process industry the operating conditions can vary substantially and the process heat exchanger equipment needs to perform adequately over a long period of time, at least between shut down cycles. Additional cleaning of the heat exchanger equipment leads to additional unwanted downtime, loss of production and in many cases complex procedures.

Dual enhanced tubes in copper and copper-nickel are widely used in cooling water systems with open cooling tower in the air-conditioning and refrigeration industry. Important for a proper functioning is the good treatment of the cooling water with respect to scaling linked to CaSO₄ deposit, particulate fouling as well as bio-fouling. Extensive studies to confirm the stable operation of distinct dual enhanced tubes with their sophisticated internal fin structures have been carried out [2, 3, 4].

In the hydrocarbon processing industry low-finned tubes have been applied successfully in fouling services in refining applications for reboiler and condensers [5, 6] as well as crude oil pre-heating trains [7]. Most of these references have been realized in debottlenecking and capacity expansion situations. Therefore these references have to be handled carefully with respect to a general acceptance for all these

services. Considering that the additional energy consumption as well as all related operational costs due to fouling are estimated to 0.25 % of the Gross Domestic Product of the industrialized countries [8], the attractiveness to improve operability of heat exchanger equipment and process units is very high.

Over the last 15 years Wieland enhanced GEWA-PB and -KS tubes in carbon steel have been applied and developed to a standard technology in Liquefied Natural Gas (LNG) and ethylene plants [1]. The primary applications are for clean refrigeration and separation processes with clean C2 and C3 hydrocarbon and refrigeration type fluids. In LNG plants these are C3 chillers and condensers for the propane pre-cooling cycle to cool the feed gas and the mixed refrigerant, respectively. For ethylene plants the preferred application is for distillation towers: reboilers and condensers as well as refrigerant condensers for the ethylene and propylene refrigerant loop.

To further broaden the application of enhanced heat transfer technologies interesting applications for both GEWA-PB and -KS tubes have been identified for heat exchanger equipments working with cooling water as well as quench water in ethylene plants.

For cooling water applications it can be referred to existing experience in the air-conditioning and refrigeration industry, thereby transferring the design information appropriately to adequate condenser or gas and liquid cooling applications in the hydrocarbon processing industry.

However in the case of quench water a further test is required to qualify dual enhanced tubes for such reboiler applications. To carry through such an industrial field test an ethylene plant operator in Europe with a naphtha cracker has been very supportive, providing the opportunity to replace an existing plain tube stab-in reboiler in a C3 stripping column by a new heat exchanger equipped with the dual enhanced GEWA-PB tubes. The pre-requirement for such a field test was the proper instrumentation with flow meter, temperature and pressure sensors.

The thermal rating of the stab-in reboiler has been carried through by Technip France Heat Transfer Dept., see **Error! Reference source not found.**

The replacement heat exchanger, has been fabricated by a local vendor with tubes supplied by Wieland..

FIELD TEST

Ethylene plant process

The purpose of a naphtha steam cracker is to produce light olefins like ethylene, propylene and butadiene, which will be used for the production of polymers, rubbers and other applications.

Naphtha, diluted with steam, is cracked in the cracking furnaces at temperatures of 800 to 850 °C resulting in a mixture of steam, hydrogen and all hydrocarbons species,

called cracked gas. The cracked gas is cooled down in several steps before being compressed in the cracked gas compressor.

One of the cooling steps includes direct contact with cold quench water, which is fed to the top of the quench water column. The hot quench water leaves the quench water column via the quench water settler at about 80°C. The warm quench water is used in downstream unit operations to recover the energy. Surplus energy of the quench water is removed by cooling water and air coolers and therefore lost to atmosphere.

The cracked gas is separated via cryogenic unit operations and distillation into different fractions, one of them being the C3 fraction at the top of the depropanizer column.

The C3 fraction contains propylene (C3H6), propane (C3H8), Methyl-acetylene and propadiene (C3H4, named MAPD). MAPD are hydrogenated to propylene and propane with hydrogen coming from cryogenic section in the MAPD hydrogenation reactor. This hydrogen stream also contains methane due to the nature of the cryogenic step.

The purpose of the C3 stripper is to remove these light components as well as remaining C2 cut that might come from external C3 sources like refinery grade propylene.

The C3 stripper is reboiled by quench water and condensed against propylene refrigerant. The reboiler is always fully submerged in the boiling C3-liquid and the boil-up ratio is controlled by the quench water flow rate. The C3 stream from a naphtha cracker usually consists of 95 wt-% propylene with 5% propane and few C4's, which is separated in the downstream C3 splitters.

Several process parameters are monitored by typical industrial grade instruments. The flow rate of the quench water and the sump draw off are measured by flow orifices. The inlet and outlet quench water temperatures are measured by PT-100 elements. Also the saturation temperature of the boiling C3 is measured at the sump draw-off by a PT-100 element.

The pressure differential in the quench water system is measured by membrane pressure transmitters.

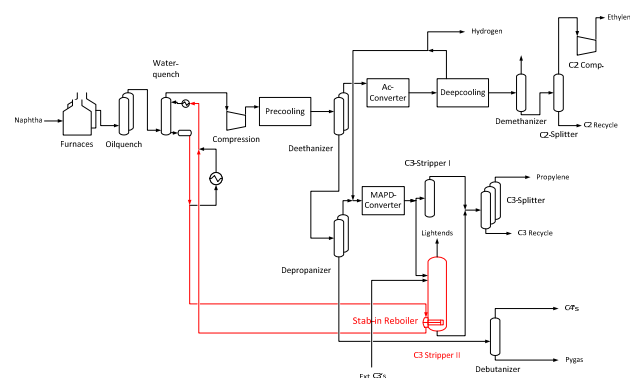

Figure 1: Plant layout of Naphtha Cracker

Quench water

In steam crackers, ethylene is obtained by thermal cracking in furnaces. The cracked gas needs then to be rapidly cooled down to prevent degradation of the product yield due to secondary cracking reactions. The final cooling (from about 175°C to 40°C) before gas compression is achieved in the two towers in series; primary fractionator followed by quench water tower. The cracked gas is cooled down in quench tower by direct contact with a closed loop of circulating quench water in the tower. The heated quench water will then be used as a heating medium, e.g. for C3 splitting applications such as the C3 stripper-reboiler.

When facing the question about the composition of the quench water, few accurate data are available today and generally the best answer you can get is “Quench water is quench water!!”.

In fact the composition of quench water will vary depending on many parameters:

- The type of cracker: gas cracking vs. naphtha cracking;
- The quality of the available water on site;
- Management of quench water clean-up (draining, filtration, etc.)

As examples some data collected on several projects from gas cracking processes and naphtha cracking processes are shown in Table 1 and Table 2.

Table 1: Examples of quench water contents from gas cracking units

Coke particles	Estimated quantity	Normal 5 / max 50 ppm wt
	Diameter	0.3 mm in average 25 mm maximum
	Estimated density	1200 kg/m ³
Tar particles	Estimated quantity	Normal 300 / max 4000 ppm wt
	Diameter	0.15 mm avg. (0.01 mm min./0.25 mm max.)
	Estimated density	1100 kg/m ³
Aromatics	Estimated quantity	1% weight



Figure 2: Tar deposits on a plate of a plate and frame heat exchanger using quench water

Table 2: Example of quench water contents from naphtha cracking unit

Component	ppm weight
Gasoline	200
Fuel Oil	400
Ethylene	Traces
Ethane	Traces
Propane	Traces

In the present case a composition analysis was performed on the circulating quench water issued from naphtha cracking process plant by the Institut Alpha [9], see Table 3.

Table 3: Composition of the quench water circulating in the stab-in reboiler

KW-Index (C-10 to C-40)	415 mg/l
Volatile aromatic hydrocarbons (Benzene, Toluene, Ethylbenzene, Xylene, Cumene & Styrene)	155 mg/l
Polycyclic aromatic hydrocarbons (Naphthalene, Acenaphthene)	153 mg/l

The KW-index [10] covers components of mineral oil between C10 and C40 with a boiling point between 175°C and 525°C. Volatile aromatics are primarily benzene, toluene, ethyl-benzene and xylene, also called BTX. They are short chain hydrocarbons not covered by the KW-index and can act as well as solvents. The polycyclic aromatics hydrocarbons cover a very wide group of thousands different components. The components stated in Table 3 belong to the group of light polycyclic aromatics. No heavier components indicating the presence of tar have been measured.

Figure 2 represents typical quench water fouling in a gas cracker plant. The industry standard of fouling management is to promote a relative high flow velocity to increase the shear stress at the tube wall thereby minimizing deposits.

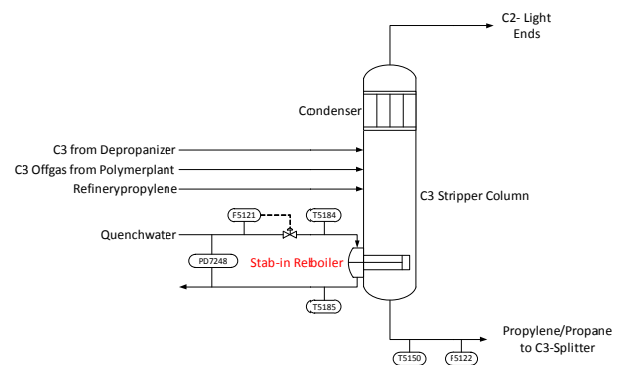

Figure 3: C3 Stripping unit with stab-in HEX and instrumentation

REBOILER DESIGN

Operating conditions

The reboiler installed at the bottom of the C3 stripping column, see Figure 3, is performing partial vaporization of a mixture made of 95% wt propylene and 5% wt propane with

traces of ethane and lighter products. It operates at 28°C and 13.5 bar abs.

The energy to the column is provided by quench water at 78 °C and 4.5 bar abs. The design duty is 649 kW.

This exchanger operates in pool boiling mode. HTRI software [11] has been selected for the design using correlations for the GEWA-PB tube developed by Technip France Heat Transfer Department and Wieland-Werke AG.

New double enhanced tube heat exchanger design criteria

When designing the new double enhanced tube GEWA-PB heat exchanger, following aspects have been considered:

1. Provide a design fully compliant with codes, standards and operator specifications;
2. Provide a heat exchanger that will suit perfectly within the same location and with the same connections as the existing one, to avoid adaptation work on site;
3. Provide the operator with a heat exchanger that will perform the required duty and meet the allowable pressure drop. Furthermore no disturbance shall occur during operation of the plant;
4. Provide a design that will allow following the behaviour of the heat exchanger with regard to quench water and specifically the double enhanced tubes.

To address first and second aspects it has been decided to keep the same shell diameter, connection size, location and to work with a heat exchanger manufacturer recommended by the operator.

Regarding the third and fourth aspects, the heat transfer area that will balance the heat transfer has been defined considering the flow regime inside tubes and the risk of fouling.

Comparison of heat exchanger geometries & design

The existing heat exchanger is a B-U TEMA type, i.e. a B type head for quench water distribution and U tubes. The design comparison of the tube bundle for both the plain and dual enhanced tube is shown Table 4.

With the 4-pass design, the quench water velocity inside the tube is of 0.31 m/s. According to Technip France Heat Transfer Department experience, the recommended water velocity should be in the range of 1 to 2.5 m/s to ensure a sufficient heat transfer and limit fouling. Since the operator allows for a higher pressure drop the 4 pass tube side design has been replaced by a 6 tube pass design. The new design with GEWA-PB tubes results in a water velocity of 1.5 m/s.

For the heat exchanger with plain tubes the inside and outside fouling thermal resistances are applied onto the bare tube areas, respectively. In the fouling conditions, the total fouling thermal resistance represents over 40% of the overall thermal resistance.

Table 4: Comparison between existing and new double enhanced tube heat exchangers

Tube Type	Plain tube (existing)	Double enhanced GEWA-PB tube (new)
Shell internal diameter (mm)	662	
TEMA heat exchanger type	B-U	
Number of U tubes	153	82
Tube outside diameter (mm)	25.00	19.05
Number of passes	4	6
Effective area (m ²) (based on outside bare area)	24.4	9.1
Tube side quench water velocity (m/s)	0.31	1.50
Internal fouling thermal resistance (m ² .K/W)	0.00026	0.00026
External fouling thermal resistance (m ² .K/W)	0.00017	0
Total fouling thermal resistance (%)	Over 40%	Over 65%

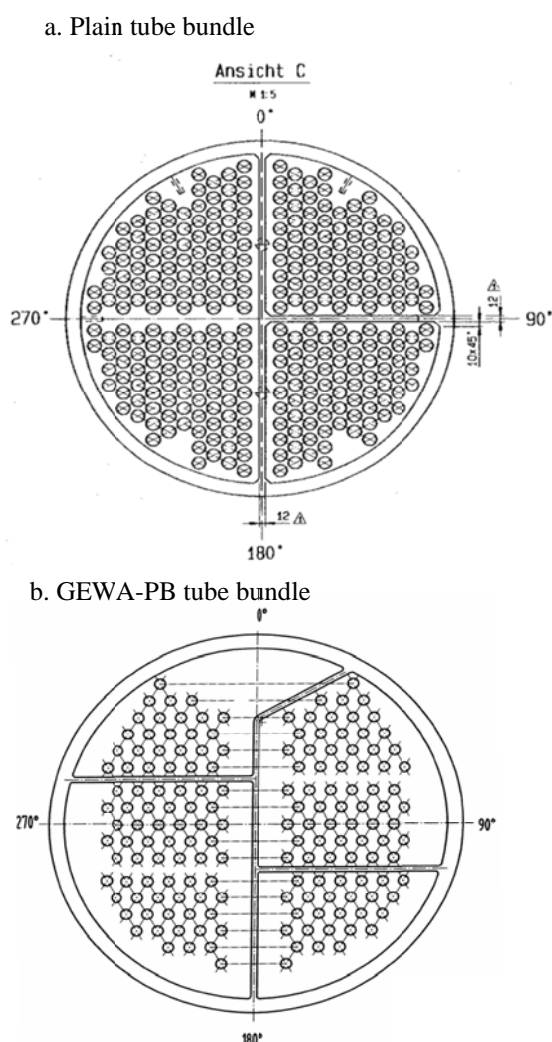

Figure 4: Tube layout of plain (a) and replacement tube GEWA-PB (b)

Since the C3 mixture is a clean product no fouling is considered for the external enhanced area. Nevertheless quench water is a fouling fluid so internal fouling resistance was kept and applied to the internal enhanced surface. However with the double enhanced surface the overall heat transfer has increased substantially, thereby increasing the contribution of the fouling resistance to the overall heat transfer resistance.

The tube pitch was also increased in order to distribute homogeneously the tube arrangement on the tubesheet and manage the increased vapor rate due to high effectiveness of the tubes, Table 4, for tubesheet layout comparison.

RESULTS

Description of raw data

While the process was running the following data were recorded every 2 hours for a period of approx. 11 months (October 2012 to September 2013):

Tube side:

- Quench water inlet temperature (T_{wi})
- Quench water outlet temperature (T_{wo})
- Quench water mass flow rate (M_w)
- Quench water pressure drop

Shell side:

- The saturation temperature of the hydrocarbon mixture.

Two methods have been used to determine the fouling heat transfer resistance. These 2 methods are described below. It should be noted that the quench water flow rate is not constant as it can be seen in Figure 5.

We also checked the possibility to follow the fouling level thanks to the evolution of the quench water pressure drop. But as this pressure drop is measured upstream the flow control valve this is the sum of the pressure drop of the valve and the pressure drop of the exchanger that is recorded and so it was not possible to use this information.

Data reduction method

The duty of the heat exchanger can be determined based on the inlet-outlet temperature difference and mass flow rate of the quench water as follow:

$$Q = M_w * C_p * (T_{wi} - T_{wo}) \quad 1$$

The duty can also be expressed as:

$$Q = U_o * A_o * LMTD \quad 2$$

Whereas the overall heat transfer coefficient (U_o) corresponds to:

$$\frac{1}{U_o} = \frac{1}{h_o} + R_w + \frac{A_o}{h_i * A_i} + R_{fo} + R_{fi} \frac{A_o}{A_i} \quad 3$$

and the wall thermal resistance to:

$$R_w = d_o \frac{\ln\left(\frac{d_o}{d_i}\right)}{2k} \quad 4$$

First method:

For this first method it was assumed that there is no fouling on the shell side. In this case equation (3) can be expressed as:

$$R_{fi} = \frac{A_i}{A_o} \frac{1}{U_o} - \frac{A_i}{A_o} \frac{1}{h_o} - \frac{A_i}{A_o} R_w - \frac{1}{h_i} \quad 5$$

The overall heat transfer coefficient U_o can be determined from equation (2). The wall thermal resistance R_w can be determined from the tube geometry and the thermal conductivity of the tube material. Further the heat transfer coefficients on the shell side (h_o) and on the tube side (h_i) are obtained from laboratory measurements with water and pure propane.

The weak point of this method is related to the slight difference between laboratory and plant process fluid qualities.

Second method:

For this second method the heat exchanger is considered as clean at start-up. In this case the overall heat transfer coefficient (U_{clean}) that will be the reference line yields:

$$\frac{1}{U_{clean}} = \frac{1}{h_o} + R_w + \frac{A_o}{h_i * A_i} \quad 6$$

When fouling arises the overall heat transfer coefficient (U_f) is expressed as:

$$\frac{1}{U_f} = \frac{1}{h_o} + R_w + \frac{A_o}{h_i * A_i} + R_{fo} + R_{fi} \frac{A_o}{A_i} \quad 7$$

Only the experimental data for which the saturation temperature is between 23°C and 28°C will be considered. Figure 5 shows that only few point at start-up (32 over 1355 points) were not in this range. Based on the actual heat flux analysis and on the laboratory measurement of the heat transfer coefficient shell side it can be considered that the heat transfer coefficient shell side is constant for all measurement data. It was assumed similarly to the first method that there is no fouling shell side.

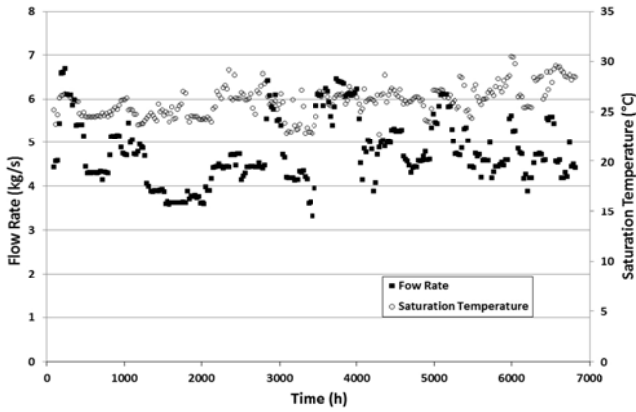

Figure 5: Quench water flow rate and mixture saturation temperature.

When the tube side heat transfer coefficient (h_i) is the same for the clean and the fouling case (i.e. same velocity), equation (6) subtracted from equation (7) yields:

$$\frac{1}{U_f} - \frac{1}{U_{clean}} = R_{fi} \frac{A_o}{A_i} \quad 8$$

Consequently the tube side fouling factor is:

$$R_{fi} = \left(\frac{1}{U_f} - \frac{1}{U_{clean}} \right) * \frac{A_i}{A_o} \quad 9$$

At this stage, the tube side fouling resistance is determined for the clean overall heat transfer coefficient (U_{clean}). Figure 6 shows the overall heat transfer coefficient vs. Reynolds number (Re). The data points with dark dots were taken during the first 190 hours after plant start-up and are considered to be under clean conditions. The measurement data taken after 190 hours are shown in white dots.

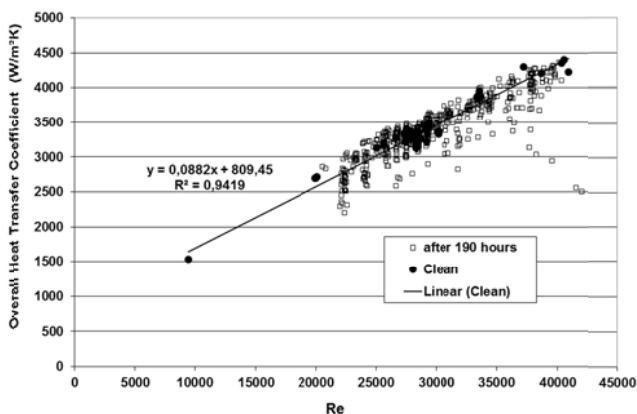

Figure 6: Overall heat transfer coefficient vs. Re

For the first 190 hours there was an excellent agreement between the overall heat transfer coefficient and the Re number (See linear correlation of dark dots in Figure 6). For

a given Re number this linear fit will give the overall heat transfer coefficient considered under clean condition (U_{clean}).

After 190 hours, it can be seen that these data are not anymore in good agreement. For a given Re number (i.e. given velocity) the overall heat transfer coefficient (U_f) decreases due to the fouling thermal resistance. In combination with equation (9) these information allow determining the tube side fouling thermal resistance.

The weak points of this method are the assumption of constant shell side heat transfer coefficient and the assumption that there is no fouling in the very first hours of operation.

Field Test Results

It is important to underline that there is some uncertainty in the measurements since the implemented instruments and their corresponding accuracy were selected to monitor the process and not to measure the fouling thermal resistance. Such as the quench water inlet and outlet temperatures are not measured directly at the inlet and outlet of the heat exchanger but a few meters away. This can be seen on Figure 3 where the quench water inlet and outlet temperatures are taken by PT-100 represented by T5184 and T5185, respectively.

In Figure 7, the fouling thermal resistance is described by two methods, described above.

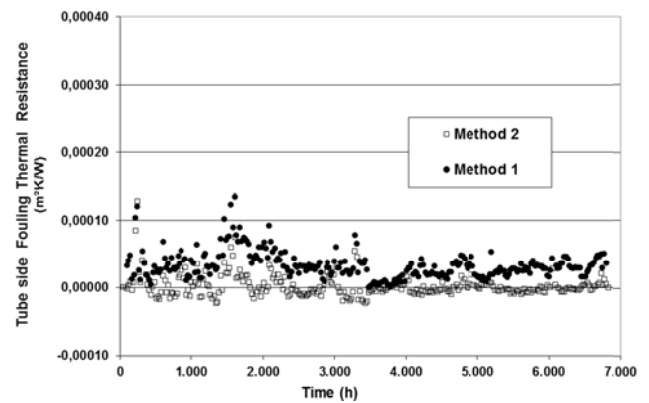

Figure 7: Fouling thermal resistance tube side. method 1-dark dots, method 2-white dots

The fouling thermal resistance calculated with the first or the second method have the same behaviour with some shift of the absolute value. It is suspected that the rapid changes of the fouling thermal resistance values over time are mainly due to transient operating conditions.

The sometimes negative fouling thermal resistance sometimes - which is not possible - is related to the way the reference line with a linear regression was determined. Even if there is fouling it should be pointed out that in all cases the fouling thermal resistance is smaller than 0.00015 m²K/W.

CONCLUSIONS

In order to study and validate the use of GEWA-PB dual enhanced tube with a fouling fluid the quench water in reboiler installed at the bottom of the C3 stripping column has been replaced in an European ethylene plant.

The new heat exchanger has been successfully operated under industrial conditions over more than 11 months.

More than 1365 operating points representing 11 months of monitoring have been collected. They have been reduced using two different approaches. In both cases, no particular fouling of the heat exchanger equipped with the GEWA-PB tubes has been identified.

Today the operator is completely satisfied by the performance of the equipment.

We will continue to collect the data and analyze them in order to improve our knowledge and ensure the follow-up but this exchanger is now become a “full production” exchanger.

The available results are promising for the use of the GEWA-PB tubes with quench water service.

ACKNOWLEDGEMENTS

The authors like to thank the operator of a naphtha cracker for the acceptance of these field trials. Due to company policy the participation of our partner could not be mentioned officially, none the less we thank for the excellent support throughout the whole project.

NOMENCLATURE

A_o	outside envelope surface at fin tip (m^2)
A_i	internal surface at internal root fins (m^2)
c_p	quench water heat capacity (J/kgK)
d_o	tube outside diameter (mm)
d_i	tube inside diameter (mm)
h_o	heat transfer coefficient shell side (W/m^2K)
h_i	heat transfer coefficient tube side (W/m^2K)
k	wall thermal conductivity (W/mK)
LMTD	Log Mean Temperature Difference
M_w	quench water mass flow rate (kg/s)
R_w	wall thermal resistance (m^2K/W)
R_{fi}	fouling factor tube side (m^2K/W)
R_{fo}	fouling factor shell side (m^2K/W)
Q	duty (W)
T_{wi}	quench water inlet temperature ($^{\circ}C$)
T_{wo}	quench water outlet temperature ($^{\circ}C$)
U_o	overall heat transfer coefficient (W/m^2K)
U_{clean}	overall heat transfer coefficient, clean condition (W/m^2K)
U_f	overall heat transfer coefficient, fouling condition (W/m^2K)

C2	hydrocarbon molecule with 2 C atoms
C3	hydrocarbon molecule with 3 C atoms

REFERENCES

- [1] Ploix B., Lang T., Application of dual enhanced Wieland tubes for Ethylene and LNG Services, 2010 AIChE Spring National Meeting, San Antonio, 21 – 25 March 2010
- [2] ANSI/AHRI Standard 550/590 (I-P), 2011 Standard for performance rating of water-chilling and heat pump water-heating packages using the vapor compression cycle, Air-Conditioning, Heating and Refrigeration Institute, 2111 Wilson Boulevard, Suite 500, Arlington, VA 22201, USA, www.ahrinet.org
- [3] R.L. Webb, N.-H. Kim, Particulate fouling on enhanced tubes, National Heat Transfer Conf. 1989, Philadelphia, August 1988
- [4] G. Hays, E.S. Beardwood, S.J. Colby, Enhanced heat exchanger tubes: Their fouling tendency and potential cleanup, ECI Symposium Series, Volume RP2, Proc. 6th Int. Conf. on Heat Exchanger Fouling and Cleaning, Kloster Irsee, June 5- 10, 2005
- [5] W.O. Webber, Does fouling rule out using low fin tubes in reboilers, Petroleum Refiner, Vol. 39, pp. 183 – 186, Gulf Publishing, 1960
- [6] J.A. Moore, Fintubes foil fouling for scaling services. Chemical Processing, August 1974
- [7] E.R. Miller, Performance of low fin tubing in asphalt service, Heat Transfer Proc. Int. heat Transfer Conf., 7th, Vol. 6, pp. 409-414, 1982,
- [8] H. Müller-Steinhagen, M.R. Malayeri, A.P. Watkinson, Recent Advances in Heat Exchanger Fouling research, Mitigation, and Cleaning Technologies, Heat Transfer Engineering 28 (3), p. 173-178, 2007
- [9] Institut Alpha GmbH&Co.KG, Dornstadter Weg 15, 89081 Ulm -Jungingen, Germany
- [12] ISO 9377-2:2000 Water quality -- Determination of hydrocarbon oil index -- Part 2: Method using solvent extraction and gas chromatography
- [11] Heat Transfer Research, Inc, 150 Venture Drive College Station, Texas 77845 USA